

[1]

1

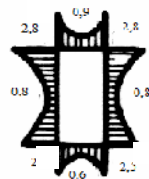
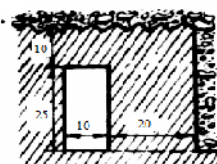
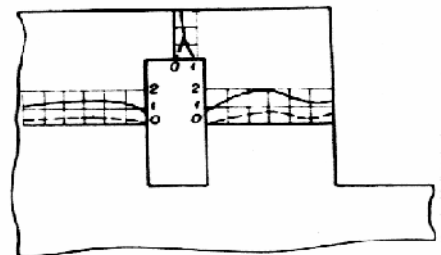
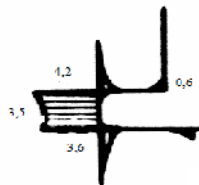
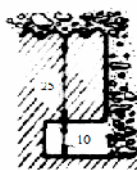
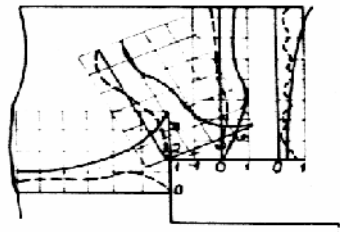
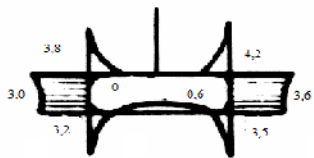
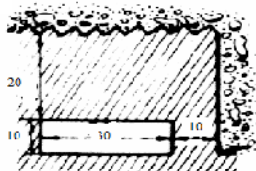
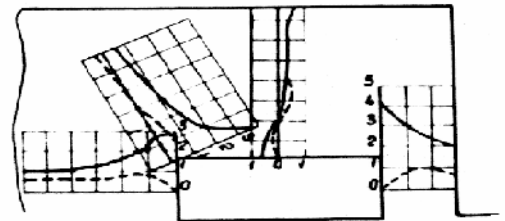
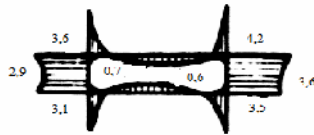
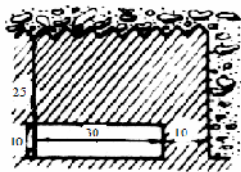

. 1.

: -

; -

; -

; -

0,3...0,4

300...400

2

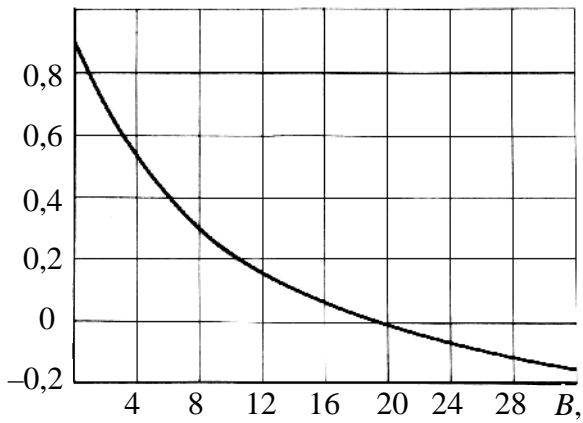

σ_x 2.

50 [2]

(0,2...0,4)

0,8...1,0

1,0,

0,4 1,0

0,3...0,39.

1 [3].

(. 3),

$$A^2 = 2RH, \quad B = H^2/2R,$$

R –

; R_c –

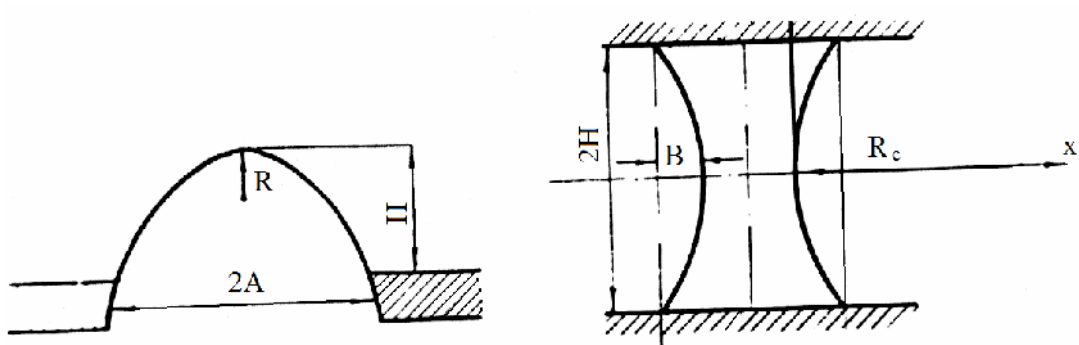

. 3.

R ,

δ

R_c

$$R = \frac{k\delta}{\gamma},$$

k –

R

σ

$$R = 0,017\sigma \quad R = 1,7f.$$

$$R_c = (1...2)R.$$

$$\alpha = 45^\circ - \varphi/2,$$

φ –

